

## The foundations of the valuation of insurance liabilities

Philipp Keller

14 April 2016



# Content

- The importance and complexity of valuation
- The basics of valuation
- Valuation and risk
- Market consistent valuation
- The importance of consistency of market consistency
- Financial repression and valuation under pressure
- Hold-to-maturity
- Conclusions and outlook

# The importance and complexity of valuation

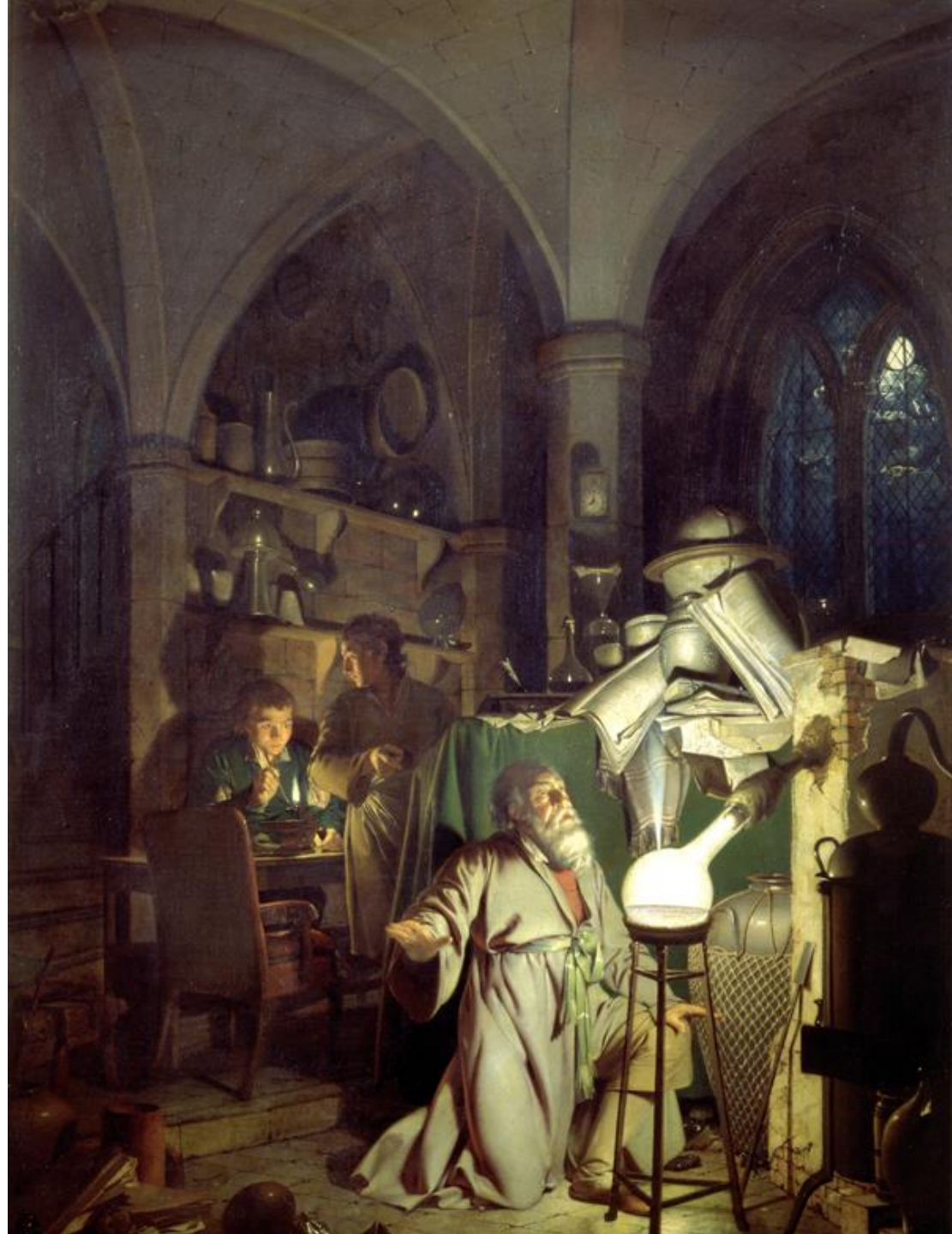

# Valuation

## Making or breaking companies and nations

**Greece:** Creative accounting and valuation and swaps allowed Greece to satisfy the Maastricht requirements for entering the EUR zone.

**Hungary:** To satisfy the Maastricht requirements, Hungary forced private pension-holders to transfer their pensions to the public pension fund. Hungary then used this pension money to plug government debts. Of USD 15bn initially in 2011, less than 1 million remained at 2013. This approach worked because the public pension fund does not have to value its liabilities on an economic basis.

**Ireland:** The Irish government issued a blanket state guarantee to Irish banks for 2 years for all retail and corporate accounts. Ireland then nationalized Anglo Irish and Anglo Irish Bank. The total bailout cost was 40% of GDP.

**US public pension debt:** US public pension debt is underestimated by about USD 3.4 tn due to a valuation standard that grossly overestimates the expected future return on pension funds' asset. (FT, 11 April 2016)

**European Life insurers:** European life insurers used an amortized cost approach for the valuation of their life insurance liability, which allowed them to sell long-term guarantee products. These products appear profitable in such an amortized cost framework, but loss making economically.

**Valuation and capital requirements for AAA rated financial instruments:** Banking regulation allowed banks to consider AAA rated exposures as risk-free, which led to regulatory arbitrage, the structuring of financial instruments such that they obtained a AAA rating, and rating agencies to become willing tools to slap high ratings on nearly any instruments. The cost of the financial crisis – of which these AAA exposures were an important but not the only cause – has been estimated by the US Government Accountability Office to be up to USD 10tn for the US alone.

# Valuation

## Nothing matters more in business and finance

Valuation standards are at the centre of insurance (and banking). They determine

- which products are sold and for which price;
- investment strategies and the potential build-up of systemic risks;
- how much profit and losses are shown based on accounting valuation;
- capitalization ratios and the amount of capital financial institutions show;
- who receives how much pension money and who has to pay for it;
- and much more.

Valuation is one of the few areas where financial mathematicians, quants and actuaries are engaged in an activity of social relevance.

For this, it is necessary to have insights into the purpose and concepts of valuation and to understand their implications.

# The basics of valuation



# The history of valuation



Āryabhata: interest rate problems in *Āryabhatīya*, ca 500 in India



Code of Hammurabi, 1800 BCE, maritime loans, number system as a basis for accounting

Song dynasty tax financing of war against Mongols

Italian city states debt financing of crusades / war against Byzantium



## Compound Interest

Bhāskaračārya, loan problems and methods of finding principal and interest in *Līlāvati*, 1150



Liber Abaci, Fibonacci, 1202

## Present Value

## Accounting



Summa de arithmetica, geometria, proportioni et proportionalità, Fra Luca Bartolomeo de Pacioli, 1494

Divergence between Asia and Europe due to differences in war financing



First bond markets, Venice



Mercantilism, Jakob Fugger, 1459 - 1525



Liber de ludo aleae, Gerolamo Cardano, 1526

## Probability Theory

## Mortality Tables

Natural and Political Observations made upon the bills of Mortality, Graunt, 1662



Value of Life Annuities in Proportion to Redeemable Annuities, Johan de Witt, 1671



Forward Contracts on Dutch East India Company

Governments sell Annuities



Probability Theory, Blaise Pascal



Oeuvres Complètes, Huygens, 1669

## Utility Theory

## Valuation by Replication



Lisbon earthquake, 1755, birth of scientific risk management

Tulip mania, 1640s



Dutch Stock Market



Office of Assurance at the Royal Exchange in London, 1575  
Contract Certainty



Specimen Theoriae Novae de Mensura Sortis, Daniel Bernoulli, 1738

Sur les rentes viagères, Leonard Euler, 1767



John Law, 1700  
Compagnie de l'Occident  
Central banking

## Economic Theory

## Classical Economics

Elements of a Pure Economics, Leon Walras, 1872

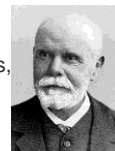

Enlightenment



# The history of valuation

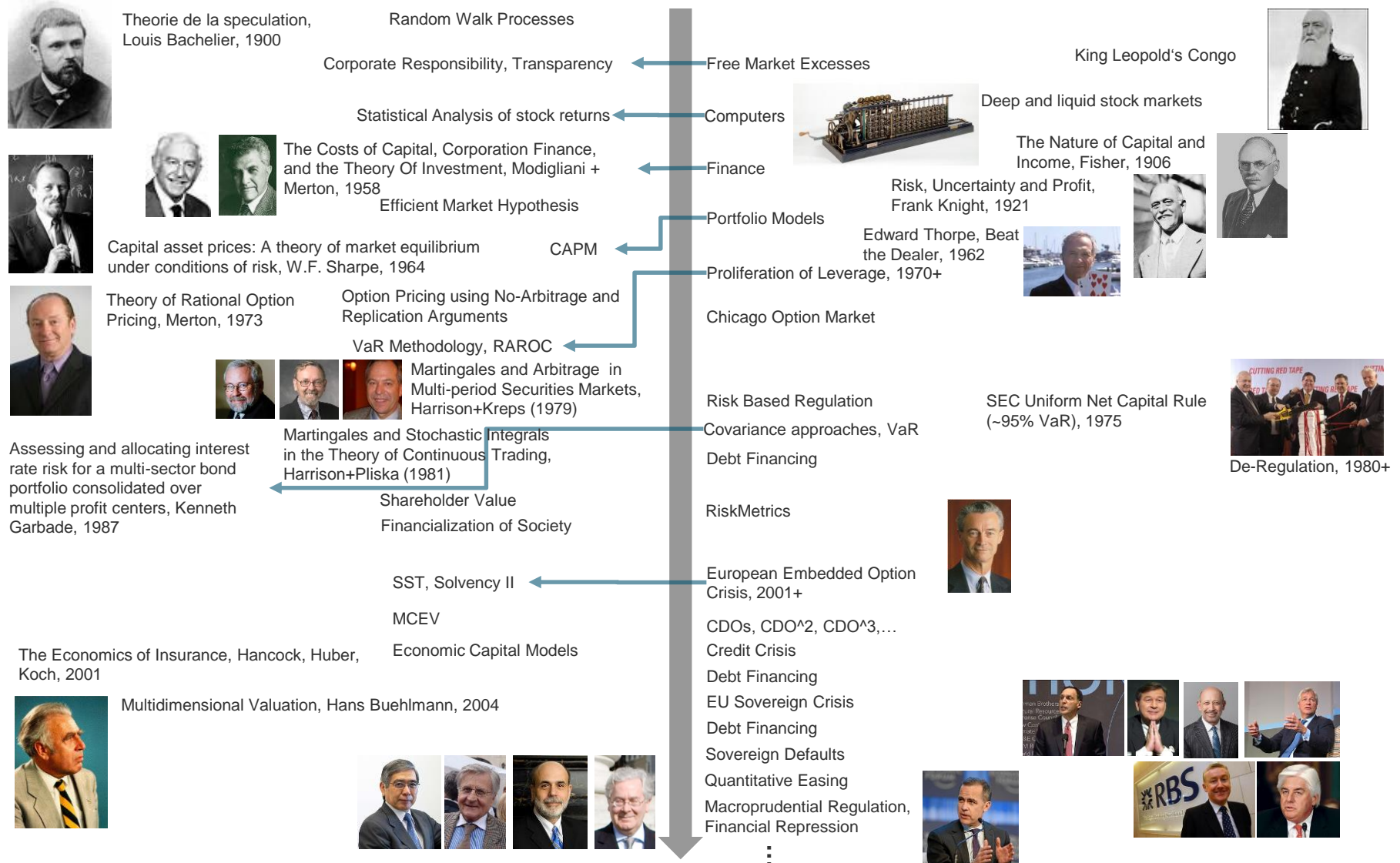



# Price, value and cost

*“Price is what you pay, value is what you get”, Warren Buffet  
“and costs are what you are stuck with.”*

**Value** is subjective. The value of owning a Maserati differs for a puritan and for a hedonist → value is what you hope for.

**Price** emerges when a seller finds a buyer and depends on the value both assign to the traded object → price is what you can get away with.

**Cost** is what has to be spent to produce the liability in an acceptable way (with acceptable security).

In deep, liquid and transparent markets, price, value and cost are close and are often used interchangeably. Market prices are an emergent property when many buyers and sellers with different preferences (i.e. different assignments of value) interact.

In reality, few securities are traded in deep, liquid and traded markets and are more or less illiquid. For the vast majority of asset and liabilities, valuation requires the use of models and cannot rely solely on market prices. Valuation determines price and costs, but not value.

Insurance liabilities are rarely if ever traded in deep, liquid and transparent markets and no market prices are available. Insurers therefore rely heavily on models for the valuation of liabilities.

# The purpose of valuation

The choice of valuation frameworks depends on the purpose. There is not one unique, mathematically predetermined value or valuation standard for financial instruments. Purposes are:

- To give information to investors (accounting);  
Publicly traded companies have to have their balance sheets externally audited so that investors and the public have an independent view of the value of the firms
- To show the profitability of current and future business;  
Management is interested not only in the current position, but also in assigning value for future business and current strategies
- To assess the cost to fulfil obligations to policyholders (insurance supervisors);  
Insurance supervisors have an interest in prudent valuation so that sufficient assets are available to cover promises to policyholders
- To give incentives for insurers to stabilize financial markets and economies (macroprudential regulators, central banks);  
Macroprudential policies to stabilize the financial market and boost the economy are being implemented to steer investments to ABS, infrastructure, banking debt, etc.
- To support financial repression, i.e. the steering of investments into desired channels;
- To establish the transfer value of a security if it were traded in a deep and liquid market;  
Initial idea of market consistent valuation standards (IFRS, Solvency II) but is not feasible, since insurance liabilities are not traded in a deep and liquid market
- To minimize value (buyer in a transaction) and maximize value (seller in a transaction).

# Valuation and risk



# Valuation

## Long-term commitments



1940

2016



Insurers and pension funds often sell liabilities with guarantees with contractual duration of decades. Some products of life insurers and pension funds can have contractual durations of 70+ years.

Austrian life insurers sell policies to 18 year olds with locked-in parameters and guaranteed annuity payments after age 65 until death. The life expectancy of a 18 year old is about 83 years. Insurers can expect to be at risk on average for 65 years, and for many policies likely much longer.



In the 1880s, a number of US states introduced pensions for soldiers injured during the US civil war (1861-1865). Albert Woolson, the last surviving soldier who participated in the civil war, died in 1956 aged 109.

Currently (2016) there is still one daughter of a civil war veteran alive in North Carolina who receives an annual pension of USD 876 due to her disablement and because she never married.

The duration of the liability exceeds 130 years.

# Insurance liabilities

## The complexity of modelling the future

“Prediction is very difficult, especially about the future.”, attributed to Niels Bohr

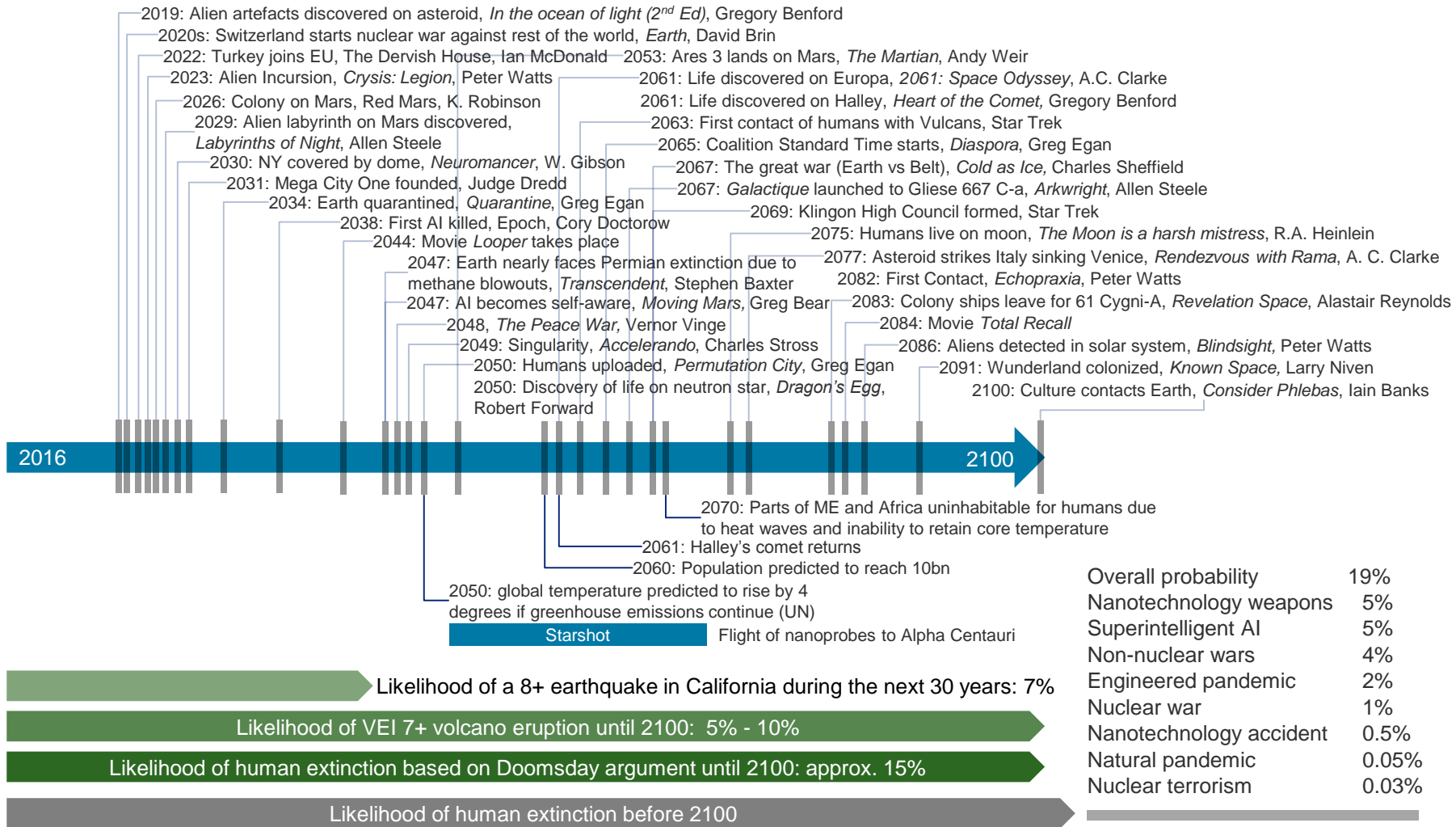

# Valuation and risk

## Two sides of a coin

Risk is the stochastic, uncertain change of the insurer's balance sheet over a given time horizon. The balance sheet changes due to external events, e.g. natural catastrophes, interest rate changes, new assumptions on longevity, etc., or internal events, e.g. operational and legal risks.

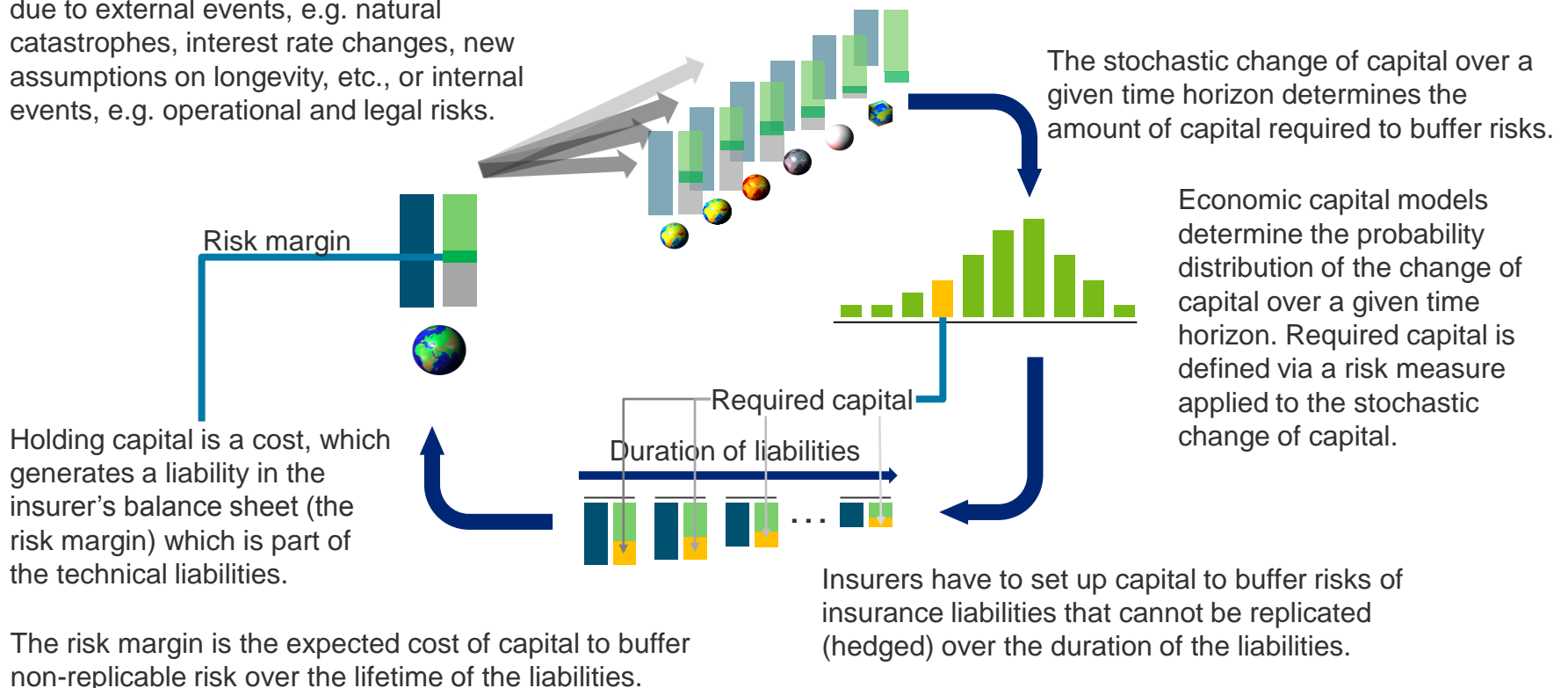

# Market consistent valuation



# Market consistent valuation

## Definitions

*A market consistent value of an asset or liability is its market value, if it is readily traded on a market at the point in time that the valuation is struck, and, for any other asset or liability, a reasoned best estimate of what its market value. Clarity before Solvency, Actuarial Association of Europe, May 2015*

*Market Consistent Valuation: The practise of valuing assets and liabilities on market values where observable with a given quality (mark-to-market), where not, on market-consistent valuation techniques (mark-to-model). Solvency II Glossary*

*The foundation for the market-consistent pricing of pension contracts is the notion of replication. Thus, if we can construct a portfolio of traded financial instruments that has exactly the same characteristics as the contract under consideration, then the market-consistent price of our contract will (by definition) be equal to the market price of the portfolio of financial instruments. Antoon Pelsser and Peter Vlaar, Market-Consistent Valuation of Pension Liabilities, 2008*

*How do you use the law of one price to determine value? If you want to estimate the value of a target security, the law of one price tells you to find some other replicating portfolio, a collection of more liquid securities that, collectively, has the same future payouts as the target, no matter how the future turns out. The target's value is then simply the price of the replicating portfolio. Emanuel Derman, The boy's guide to pricing and hedging, 2003*

The notion of a synthetic instrument, or replicating portfolio, is central to financial engineering. We would like to understand how to price and hedge an instrument, and learn the risks associated with it. To do this we consider the cash flows generated by an instrument during the lifetime of its contract. Then, using other *simpler, liquid instruments*, we form a portfolio that replicates these cash flows exactly. This is called a *replicating portfolio* and will be a *synthetic* of the original instrument. The constituents of the replicating portfolio will be easier to price, understand, and analyze than the original instrument.

Second, the instruments themselves may exist, but they may not be *liquid*. If the components of a theoretical synthetic do not trade actively, the synthetic may not really replicate the original asset satisfactorily, even though sensitivity factors with respect to the underlying risk factors are the same. For example, if constituent assets are illiquid, the price of the original asset cannot be obtained by “adding” the prices of the instruments that constitute the synthetic. These prices cannot be readily obtained from markets. Replication and marking-to-market can only be done using assets that are liquid and “similar” but *not identical to the components of the synthetic*. Such replicating portfolios may need periodic adjustments.

Principles of Financial Engineering, Salih N. Neftci, 2008



# Market consistent valuation

## A long history



1.  
Ayant établi le véritable principe sur lequel il faut fonder le calcul des rentes viagères, je crois que le développement de ce calcul ne manquera pas d'être fort intéressant, tant pour ceux qui voudront entreprendre un tel établissement que pour ceux qui en voudront profiter. J'ai ébauché cette matière dans mes Recherches générales sur la mortalité & la multiplication du genre humain, où j'ai exposé la juste méthode de déterminer par le calcul, combien un homme d'un certain âge doit payer, pour jouir pendant toute sa vie d'une rente annuelle donnée. Mais, puisque le calcul me paroissoit alors fort embarrassant, je ne pouvois pas me résoudre à l'exécuter. Or une certaine occasion m'obligea dernièrement d'entreprendre ce travail, dont, moyennant quelques artifices pour abrégér le calcul, je suis heureusement venu à bout.

2. Il y a deux choses, sur lesquelles la détermination des rentes viagères doit être fondée: l'une est une bonne liste de mortalité, qui nous montre, pour chaque âge, combien il en mourra probablement pendant le cours d'une ou plusieurs années: l'autre est la manière dont l'entrepreneur peut faire valoir l'argent qu'il aura reçu des rentiers: ou à quels intérêts il est en état de le placer. Ces deux articles concourent très essentiellement à déterminer les rentes auxquelles l'entrepreneur pourra s'engager, tant par rapport à la somme qui lui a été payée d'abord, que par rapport à l'âge du rentier. Car il est évident, que plus l'entrepreneur peut retirer de profit du capital,

X 3

Originally published as *Sur les rentes viagères*,  
Memoires de l'academie des sciences de  
Berlin 16 (1767), 165-175

In pricing annuities, Leonhard Euler linked the cash flow of annuities with the return that can be achieved by bonds in the financial market. This is one of the earliest, if not the earliest, explicit replication approach for pricing and valuing insurance liabilities.



*If the entrepreneur was not in a state to place rather well the capital which is paid to him by the annuitants, he would know how to accord only some annuities so mediocre, that no person would wish to acquire them. Another time the city of Amsterdam has paid ten per cent of annuities to all the persons below twenty years, or else for 1000 florins it has paid 100 per year to them; this which is an annuity so rich that the city would have suffered a very considerable loss from it if it had not won nearly 10 percent per year from the funds that this enterprise had procured for it. Thus, if one could rely only on 5 percent interest, the annuities must become considerably much less; however it is thereupon that it seems that it is necessary at present to regulate the life annuities, expecting that those who will have occasion to make from them a greater profit, will be scarcely troubled from one such enterprise, which would know how to be achieved only after a great number of years.*

Source: Richard J. Pulskamp, Department of Mathematics & Computer Science, Xavier University, Cincinnati, OH. November 15, 2009

# Market consistent valuation

Market consistent valuation is natural for valuing insurance liabilities. Insurers receive premiums from policyholders in exchange for payments for specified, uncertain events. The premiums are exchanged for financial instruments with which the insurers have to produce the uncertain insurance liability cash flows.

The market consistent value of the insurance liability is then the cost of producing the uncertain liability cash flows in an acceptable way using financial instruments.

The insurance liability cash flows is decomposed into two components: One component that can be perfectly replicated in all future states of the world – **the replicable component** and the remainder – the **non-replicable component**.

Insurers have to set up capital to buffer the risk from non-replicable component. The expected cost of this capital is covered by the **risk margin**. The market consistent value of liabilities is defined as the market value of the financial instruments that replicate the perfectly replicable component of the cash flow plus the risk margin.

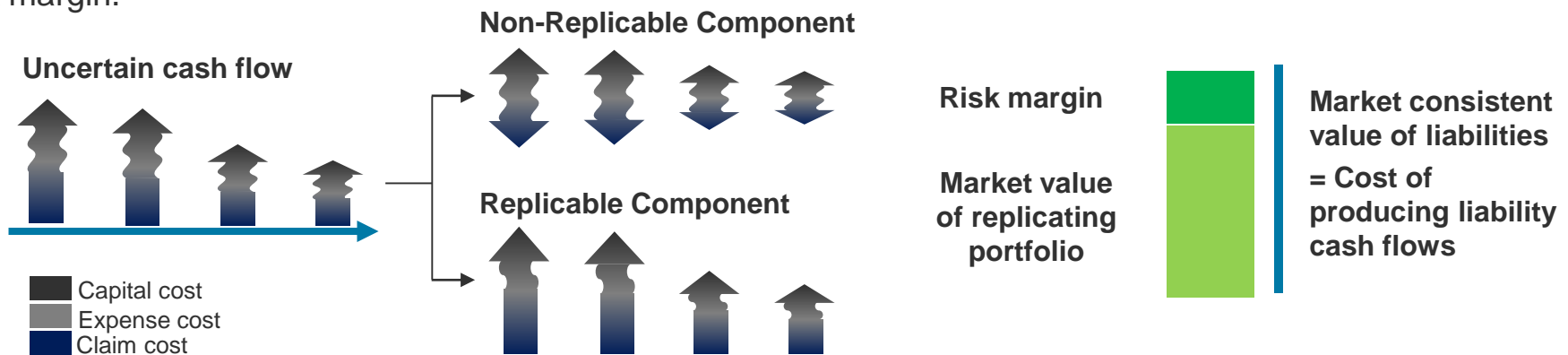

# Market consistent valuation

## The centrality of the risk margin

The risk margin is equal to the expected cost of having to hold solvency capital for non-hedgeable risk (cash flows generated by risk that cannot be replicated by financial instruments) during the life-time of the insurance liabilities.

The risk margin requires the determination of the change in market consistent value of the replicating portfolios over 1-year time-intervals

Balance sheets at  $t=3$  for all possible states of the world at  $t=3$ , given information at  $t=2$

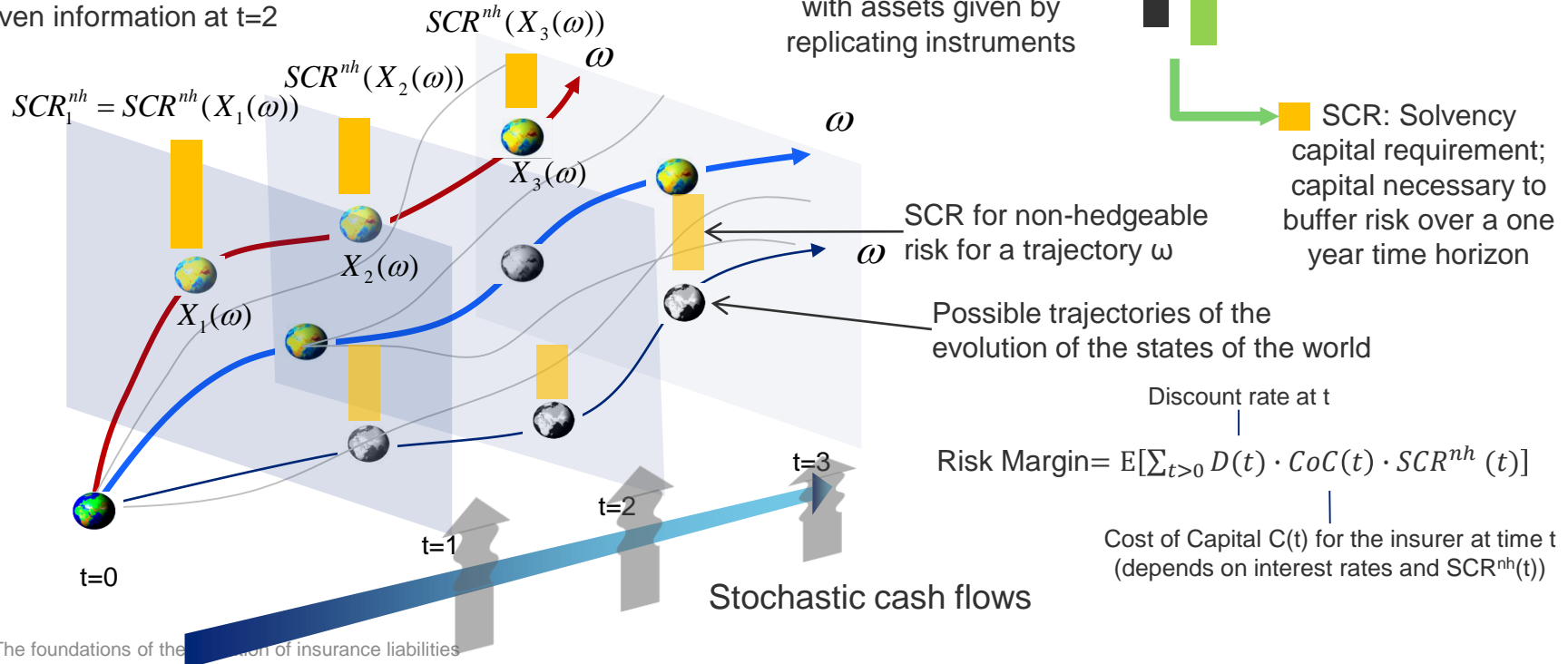

# The importance of the consistency of market consistency

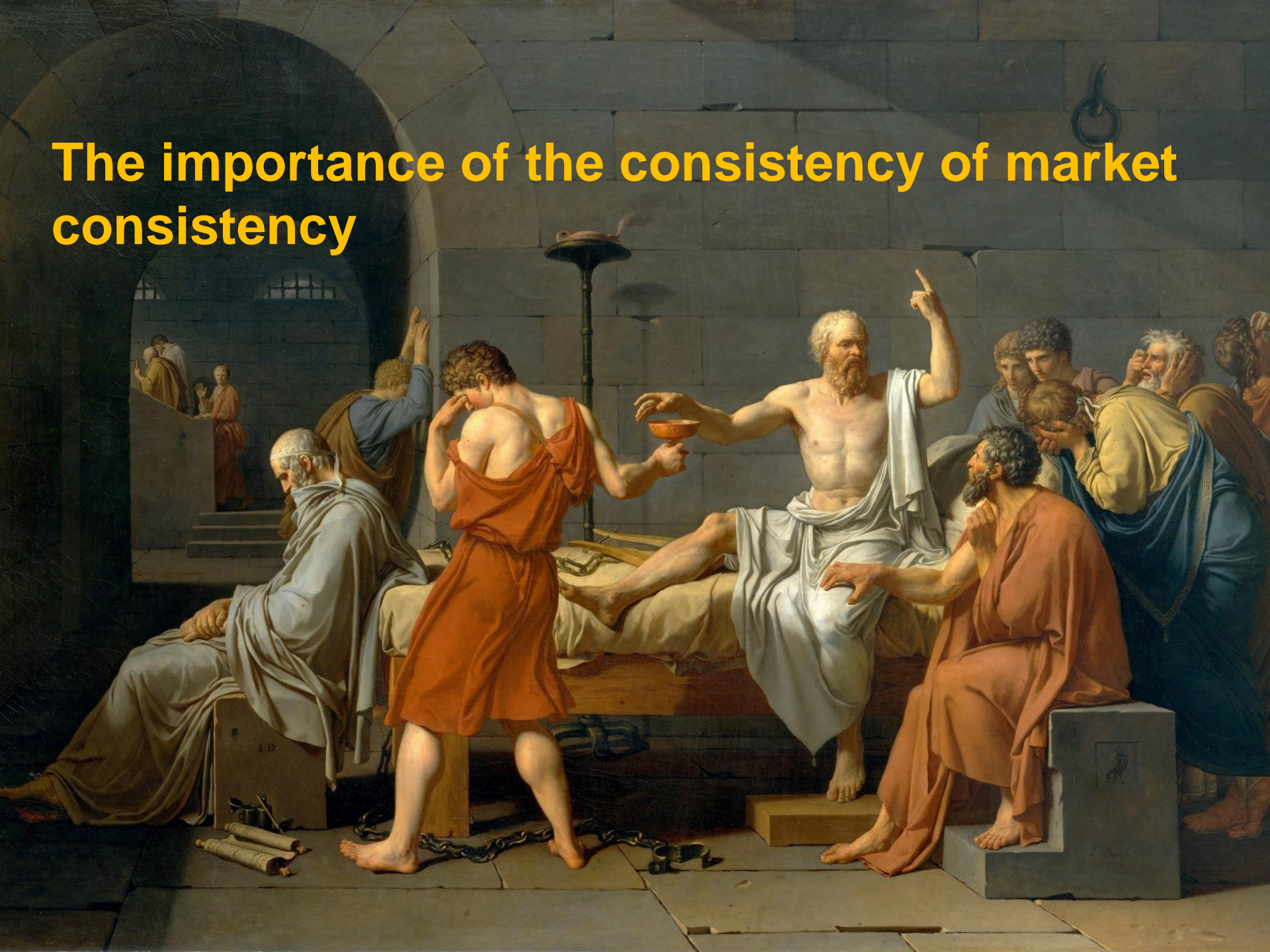

# Market consistent valuation

## Consistency requirements

Market consistent valuation requires a number of assumptions that should be based on the reality of the financial market and the business model.

The two key choices are:

- **The replicating instruments.** Which financial instruments are suitable for replication: Default-risk free bonds or liquid corporate bonds or the actual assets backing the liabilities;
- **The type of replication.** Dynamic replication (assuming regular rebalancing of the replicating portfolio) or static replication.

The dependencies show that assumptions cannot be changed without having impact on the risk margin and therefore on the market consistent value of liabilities.

- Element that have to be specified
- Element that are derived

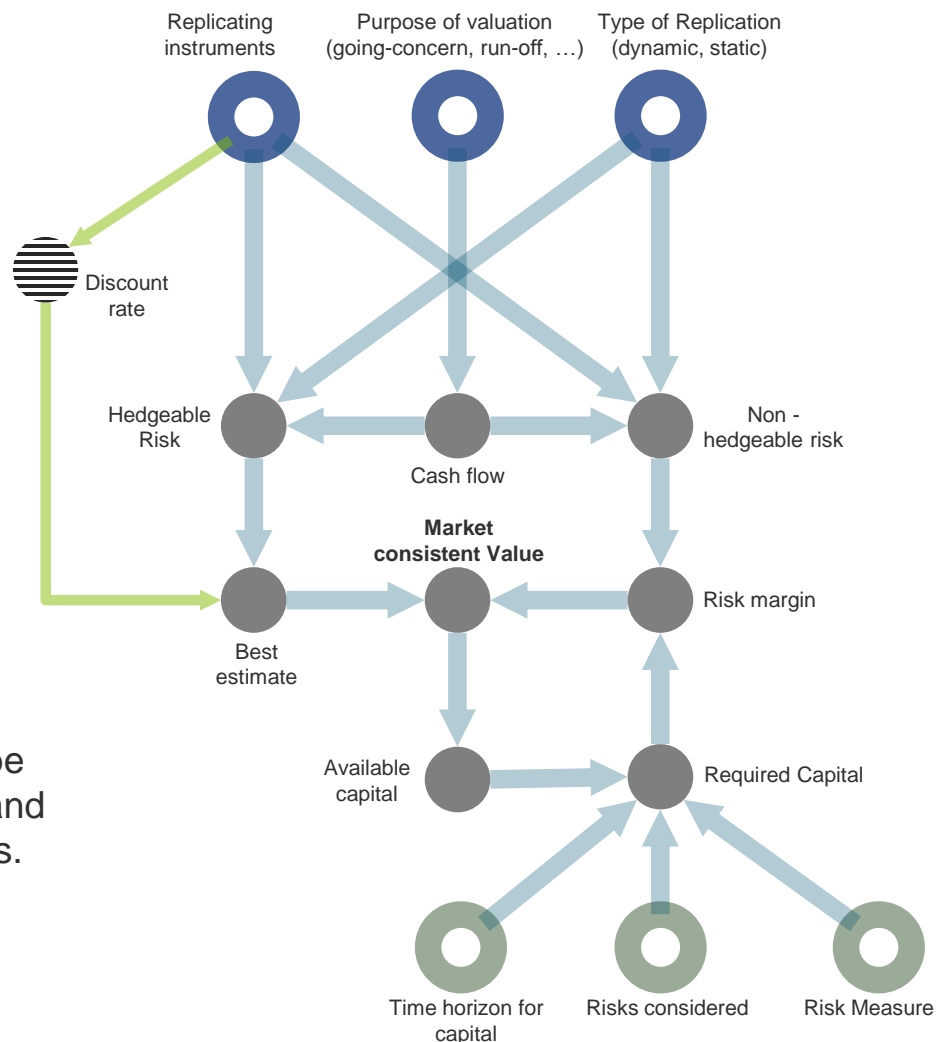

# Market consistent valuation

## The choice of replicating instruments

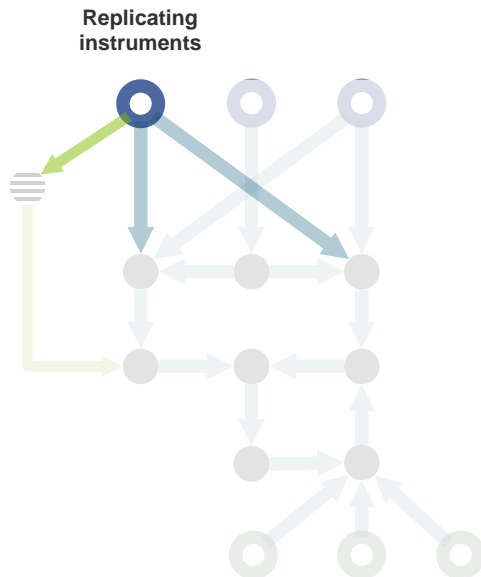

There are many choices of financial instruments to be used for replicating insurance liability cash flows:

- Default-risk free government bonds
- Highly rated bonds;
- Default-risky bonds;
- Illiquid bonds;
- Own assets of the insurer;
- Equities used as bond-like investments;
- Hypothetical financial instruments.

The further down the list, the less appropriate the replicating instruments become.

Replicating instruments ideally are as free from default risk as possible and are traded in deep, liquid and public markets so that they have reliable market prices. Illiquid financial instruments are not suitable for replication since they don't have reliable market prices.

Hypothetical financial instruments

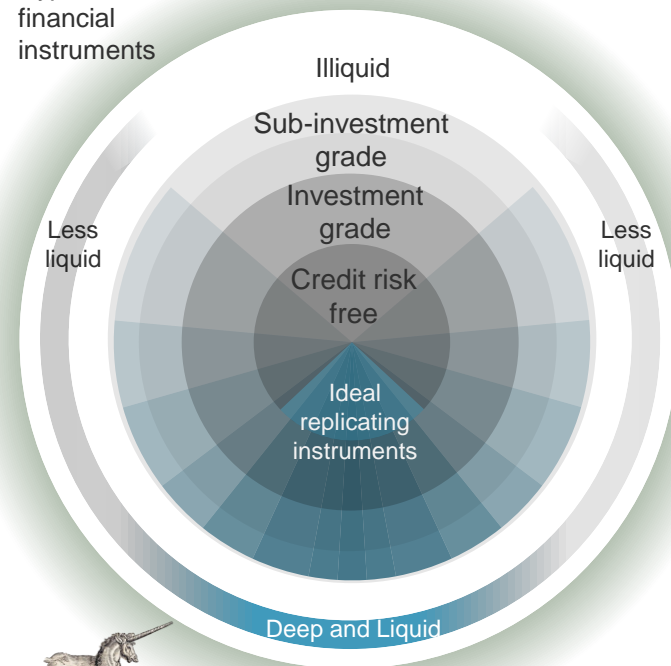

Using hypothetical financial instruments is the most inappropriate choice of replicating instrument, but quite often the case by existing valuation standards.

# Types of market consistent valuation

## Different trade-offs

Different degrees of market consistency can be distinguished by the type of replication and the replicating instruments being used. The riskier and more illiquid the replicating instruments, the smaller the market value of the replicating portfolio (often called the 'best estimate') and the higher the risk margin.

**In reality, market and valuation risks of risky and illiquid replicating instruments are rarely captured in the risk margin, which implies that these frameworks lead to lower values than a proper market consistent valuation standard would yield.**

Example	Replicating instruments	Market consistency	Non-replicable component of the cash flow	Market value of replicating portfolio + risk margin	Properties
Swiss Solvency Test, parts of Solvency II	Default risk-free sovereign bonds				High valuation certainty, small risk margin
Parts of Solvency II	Default risky bonds				Lower valuation certainty, complex calculation of market and credit risk as part of the risk margin
Countercyclical dampener of Solvency II	Illiquid bonds and other instruments				Low valuation certainty, very complex calculation of market and credit and liquidity risk as part of the risk margin
US insurance valuation, matching adjustment of Solvency II	Own assets				Low valuation certainty, very complex calculation of market and credit, reinvestment risk and often liquidity risk as part of the risk margin
Many pension valuation frameworks, some MCEVs	Hypothetical assets			?	?

# Financial repression and valuation under pressure





# The financial system

## Entering a new structural phase?

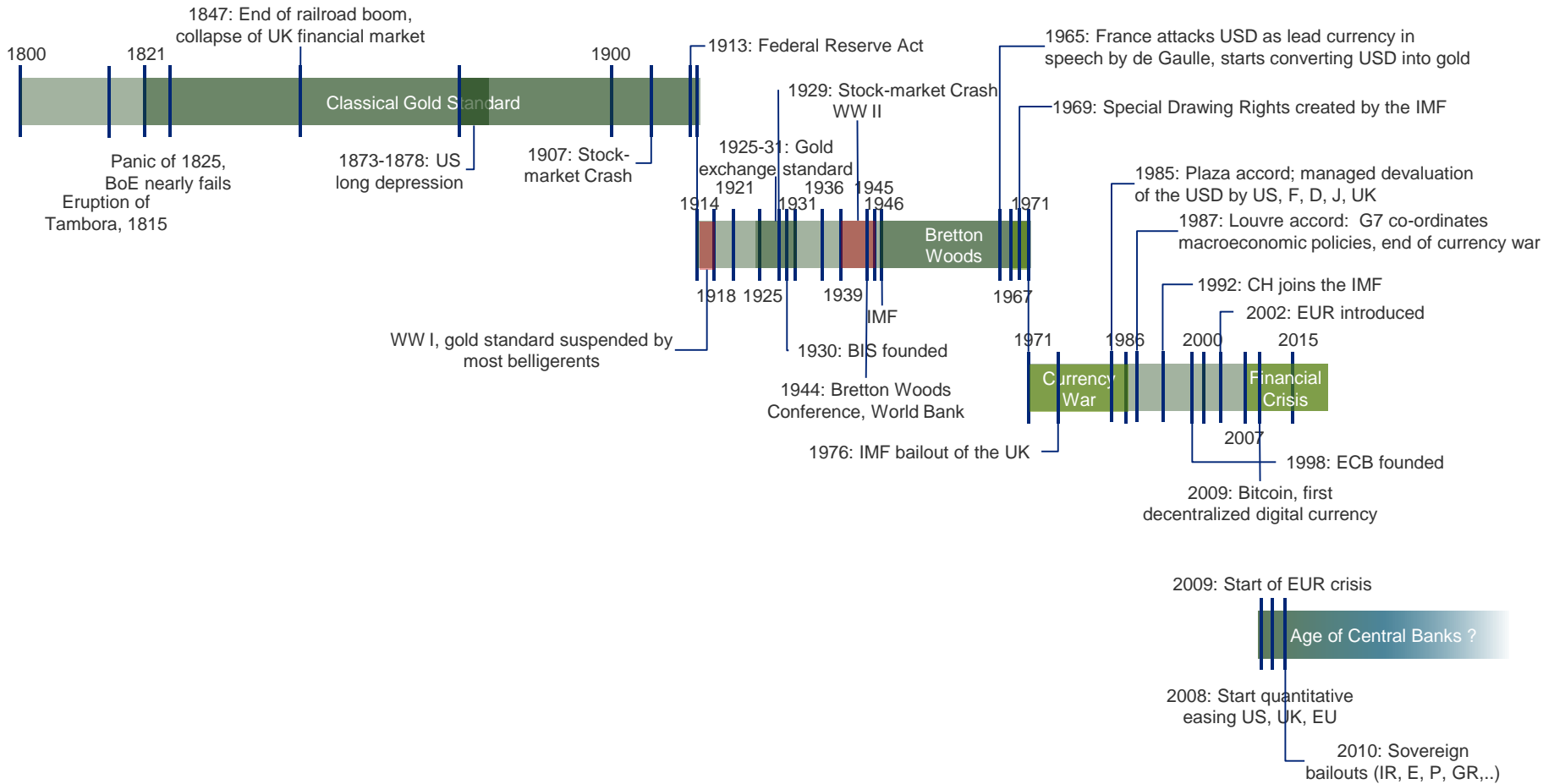

# The financial market today

## Putting the Soviet planned economy to shame

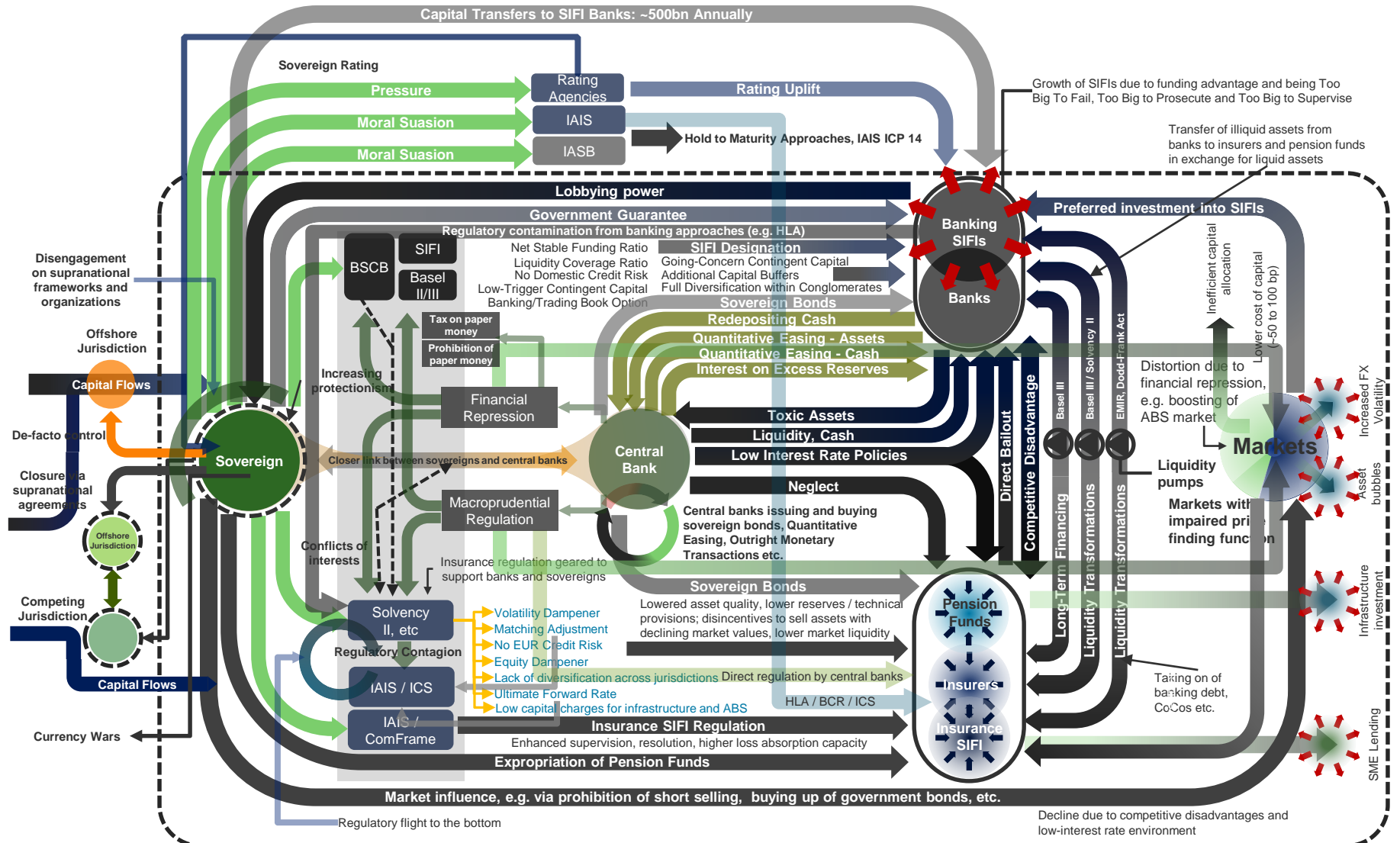

**Protectionist measures: Capital flow restrictions, trade barriers, hurdles for foreign investment, etc.**

# Sovereign risk

## Historical solutions



Seizing property of all Jews in Burgundy to Joan, his wife in 1320

Philipp V of France



Seizing of property of Jews in 1287; Edict of expulsion in 1289 to make tax increases more popular

Edward I of England, 1272 to 1307



The great exile of 1306 (Expulsion of the Jews)

Pastoralis Praeeminentiae 1309: burning of the Templars

Philip the Fair, French King, 1285 to 1314



Introduced death letters to cancel debt to Jews for a fee

Frederick I, Duke of Austria, 1308 to 1330



Annulled all outstanding debt to Jews 1384

Wencelaus IV (the Idle), German King from 1378 to 1419



Expulsion of 1394

Charles VI (the beloved), French King from 1389 to 1422



Imposed taxes on Jews to finance his wars before murdering them in 1420.

Albert the Magnanimous, Duke of Austria, 1404 to 439



Décret infâme, 1808 (reduction, postponement or annulment of all debts with Jews)

Napoleon I

## Serial offenders

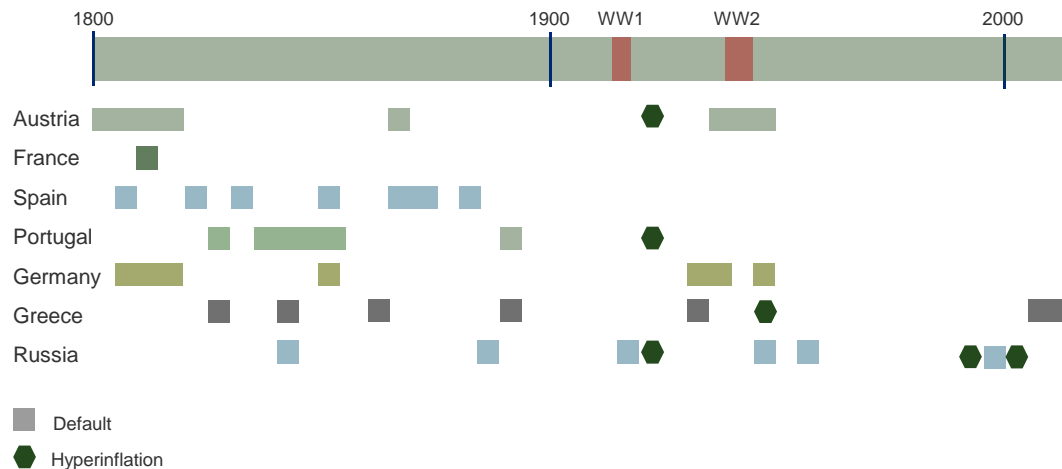

Other more conventional solutions are: Quantitative easing, increasing taxes, reducing benefits, stealing pensions from tax-payers (e.g. Hungary in 2010), misapplication of law (the use of anti-terror laws by the UK to freeze assets of Icelandic corporates), debasing the currency or outright internal and external defaults

# Sovereign risk

## Sovereign defaults and other misdemeanors

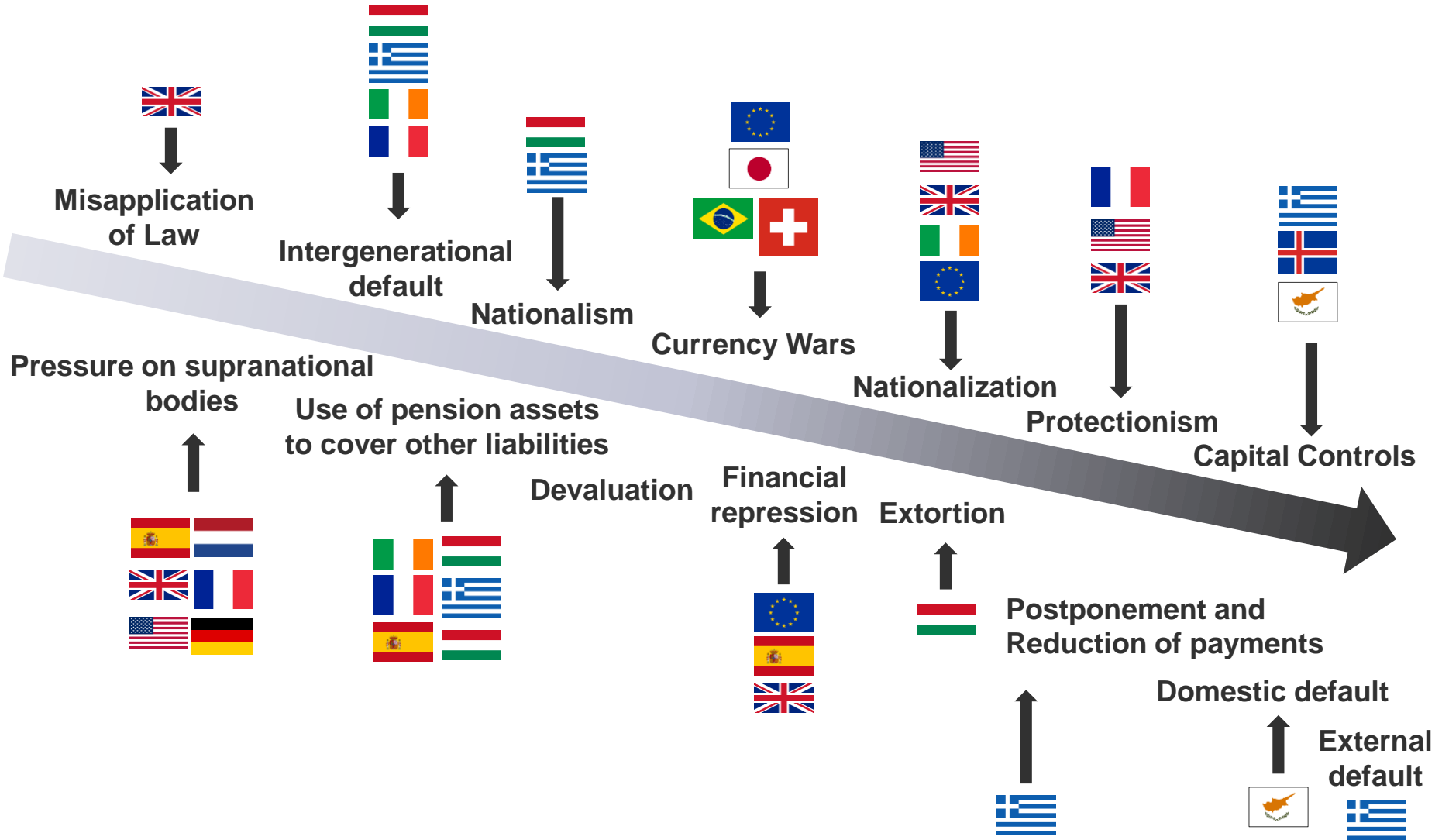

# Life insurers and pension funds

## Piggy banks and gamblers

Some of Britain's biggest banks have begun quietly ridding themselves of billions of pounds of assets they have found difficult to sell following the financial crisis, moving them off their balance sheets and into staff pension funds. [...] "The pension scheme has the ability to take liquidity risk with assets that aren't liquid temporarily," Mr Clark [head of HSBC's pension solutions group] said. Pension funds' liabilities are long-term, so short-term illiquidity is unimportant.

[Banks shift assets to cut pension deficits, Financial Times, 21 August 2011](#)

The influential London Pension Fund Authority has sold virtually its entire portfolio of UK gilts and swaps, raising the prospect of further sell-offs across the city.

Edmund Truell, founder of private equity house Duke Street Capital and chairman of the £4.8bn LPFA scheme, said: "We are in a position where we do not have enough assets to meet our liabilities. If our rate of return [on gilts] is 3 per cent before inflation, probably nothing after inflation, we are not going to be able to pay the pensions. Therefore we are safely guaranteeing bankruptcy by investing in gilts. "I don't consider gilts to be an appropriate investment for an underfunded pension fund."

[London pension body sells entire stock of UK gilts, Steve Johnson, Financial Times, March 16, 2014](#)

European insurers are the largest institutional investors in Europe's financial markets. It is crucial that prudential regulation should not unduly restrain insurers' appetite for long-term investments, while properly capturing the risks. [...]

Of particular significance is the identification of a high-quality category of securitisation based on the criteria set out in the European Insurance and Occupational Pensions Authority (EIOPA)'s advice on high-quality securitisation from December 2013). It will encourage insurers to invest in simpler securitisations, which are more transparent and standardised, thereby reducing complexity and risk and promoting sound securitisation markets which are needed by the EU economy.

Other specificities of the standard formula to stimulate long-term investment by insurers include:

- favourable treatment of certain types of investment funds that have been recently created under EU legislation [...]
- on the same grounds, a similarly favourable treatment of investments in closed-ended, unleveraged alternative investment funds, which captures in particular other private equity funds and infrastructure funds that do not take the form of one of the European funds mentioned above; [...]
- investment in infrastructure project bonds are treated as corporate bonds, even when credit risk is tranching, instead of being treated as securitisations. [...]

[European Commission - Fact Sheet Solvency II Overview – FAQ, Brussels, 12 January 2015](#)

# Valuation

## As a tool for financial repression

The choice of the valuation standard being used for regulation and public accounting has an massive impact on insurers' strategy, asset allocation and capital position.

Adapting the valuation standard is one of the most important and powerful tools for financial repression and for macroprudential policies. Seemingly small changes in methodology and parameters can have an immediate impact.

Examples:

- Using static replication / hold-to maturity gives incentives to invest in illiquid assets, e.g. infrastructure, ABS, risky corporate bonds, etc.;
- Using static replication / hold-to maturity essentially move risks to the future, which allows to postpone having to take actions on a toxic balance sheet;
- Choosing illiquid replicating instruments (and not covering the risks in the risk margin) gives incentives to invest equally risky, and generates fiat capital for insurers;
- Using own assets as replicating instruments (and discounting with the expected asset returns) gives incentives to invest as risky as possible to reduce the technical liabilities;
- Macroprudential dampeners (which reduce the cost of liabilities in economic downturns) allow to take on more investment risks with the aim to boost the economy.

# Hold-to-Maturity

Eyes wide shut



# Market consistent valuation

## Dynamic replication versus hold-to-maturity

While the choice between dynamic and static replication (hold-to-maturity) might seem arcane, it is an epic battle field in the insurance industry.

Hold-to-maturity assumes that assets (usually bonds) backing liabilities are held and not sold. This implies that changes in the market value (or spreads) are not relevant apart from the component of the spread due to default risk.

This is equivalent with discounting the liability cash flow with the risk free rate plus the spread of the bond less a small haircut for pure default risk.

The is again equivalent to bring forward all the expected returns of the asset to the time of valuation.

**Dynamic replication**

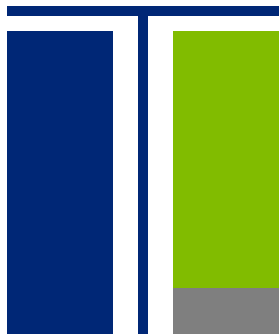

**Hold-to-maturity**



The expected asset return is a virtual asset that is used to reduce the liabilities and that can be distributed immediately to

- current shareholders and policyholders (insurers)
- current pensioners (pension funds)
- current management (banks)



# Market consistent valuation

## Dynamic replication versus hold-to-maturity

### Dynamic replication approach

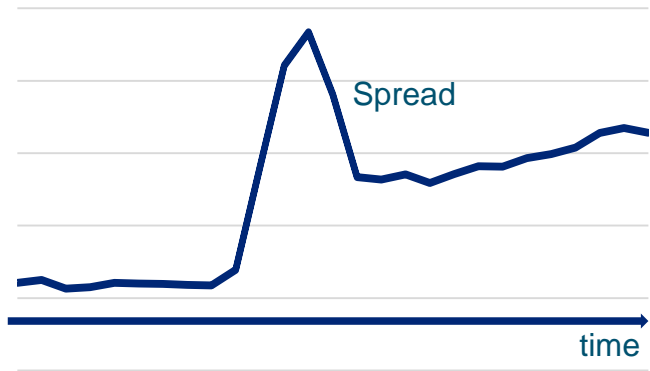

Dynamic replication approaches assume that assets might have to be sold and exchanged for other assets.

Market prices and spreads are then relevant and are considered in the valuation (in the risk margin) and in capital requirements.

### Hold-to-maturity approach

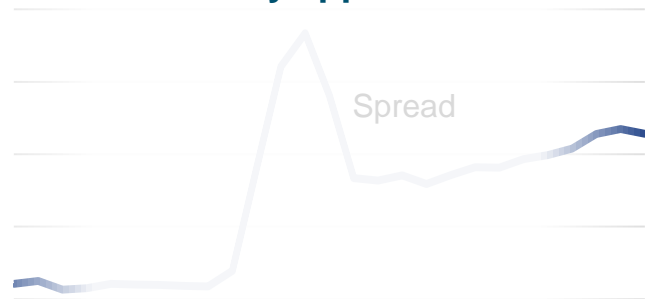

Hold-to-maturity approaches assume that assets (usually bonds) are held and not being sold. This is used as an argument that changes in market prices are irrelevant and that spread risk (apart from default risk) is irrelevant.

Spread risk is then seen as irrelevant and not considered in the risk margin or in capital requirements.

The discount rate used for valuation is based on the expected return of the assets (less a spread for default risk).

Asset price changes are not considered in a hold-to-maturity view

# Hold to maturity

## Markets assert themselves eventually

*It's only when the tide goes out that you learn who has been swimming naked, Warren Buffet*

Annual reporting requirements are based on market values of assets or at least contain information on fair value.

Investors punishing insurers with illiquid assets in times of market stress (AIG, Aegon, Fortis, ING, Swiss Re)

Consistently implemented hold-to-maturity imply that the insurer gives up management options to rebalance its asset portfolio

Lack of perceived need for own valuation models due to hold-to-maturity perspective leading to excess risk taking (AIG)

Uncertainty of value of illiquid assets resulting in supervisory interventions (Aegon)

Policyholders lapsing, resulting in the need to sell assets (Ethias)

Putting all expected profits from assets forward leads to early distribution to current shareholders, pensioners, policyholders and management and leaves others in the future to pay for the bill in case of adverse deviations

Rating agencies downgrading firms with impaired and illiquid asset in times of market stress (AIG, Aegon, ING, Swiss Re, Monoliner, ...)

Collateral calls due to rating triggers requiring transfer of assets to market values (AIG, Conventum)

Illiquid assets resulting in valuation disagreements in collateral calls (AIG/GS)

Market stress, leading to widening of spreads

During market stresses, market values cannot be disregarded anymore

Permanently impaired assets metastasizes a liquidity into a solvency problem (AIG)

Downgrades of assets leading to the necessity to sell and acquire higher rated ones based on regulatory or internal investment requirements

Intra-group transactions leading to the requirement to transfer liquid assets (CLICO)

Underestimation of default risk and cost of capital in during systemic risk events not reflected

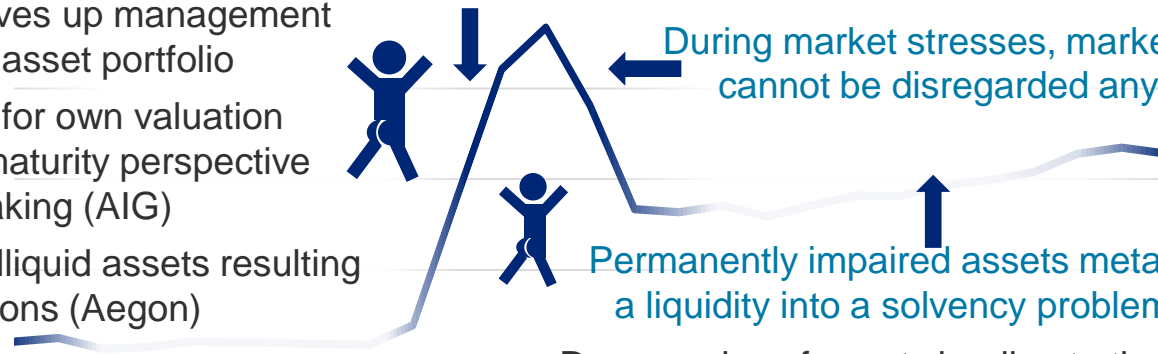

# The case for the importance of market values made by AIG and ACA

If AIG fails, policyholders are likely to seek to “cash in” policies, placing enormous strain on the insurance system, as well as bond and equity markets as assets are liquidated to pay policyholders

- Surrender of insurance policies at above-normal actuarial rates could impair current policyholders as capital, along with state guarantee funds, might be insufficient to pay all policyholder claims
- Third-party sellers of AIG products would face an unmanageable spike in customer redemption demands, damaging consumer confidence
- Forced sales of assets would be required to cover withdrawals

## Consequences of Failure

- Failure would produce an immediate “run on the bank,” which would likely lead to state seizures of local operations, causing a lock-up in customers’ retirement accounts and payment of monthly/quarterly annuity checks

Consequences of a failure of AIGCI include:

- AIGCI would immediately write less business and many businesses would cancel their existing policies, causing a substantial impact on cash flow

An AIG failure could have similar or worse consequences on the global financial markets as that of the Lehman bankruptcy. Similarities include:

- Widespread impact of ratings downgrades
  - Certain AIGFP contracts include a ratings downgrade as an “event of default;” all AIGFP contracts include bankruptcy as an “event of default,” providing a termination right to each counterparty
  - Downward pressure on values of underlying assets resulting from terminations of and the calls pursuant to the underlying and associated contracts

Source: [AIG: Is the Risk Systemic?, AIG presentation, 2009](#)

---

As Alan Roseman, CEO of ACA, told FCIC staff: “We never expected losses. . . . We were providing hedges on market volatility to institutional counterparties. . . . We were positioned, we believed, to take the volatility because we didn’t have to post collateral against the changes in market value to our counterparty, number one. Number two, we were told by the rating agencies that rated us that that mark-to-market variation was not important to our rating, from a financial strength point of view at the insurance company.” (ACA is currently has been taken over by supervisors and is in run-off)

*The Financial Crisis Inquiry Report* by the Financial Crisis Inquiry Commission, January 2011

# Conclusions and outlook



# Outlook

## Many open problems

The market consistent valuation of insurance liabilities poses many open problems, ranging from the conceptual to question on implementation:

- What are acceptable risks that a valuation framework should consider and what are good acceptability criteria?
- How to make valuation more proof against systemic risk events?
- How to define a valuation methodology that reduces the risk to take on too much systemic risk and that makes the potential cost to tax payers transparent?
- What are the economic costs of incentives given by valuation standards for insurers and for society?
- What are acceptable choices for replicating instruments: the trade-off between a small set of default risk free bonds or a wider set of riskier instruments that might replicate a larger component of the liability cash flow?
- How to model the economy over many years or decades in a situation where central bank policies drive large parts of the financial market and the price finding mechanism of the financial market is impaired?
- How to determine the risk margin: How to quantify the expected cost of future required capital, where the required capital is path dependent?

# Outlook

## Financial crises: The norm rather than the exception

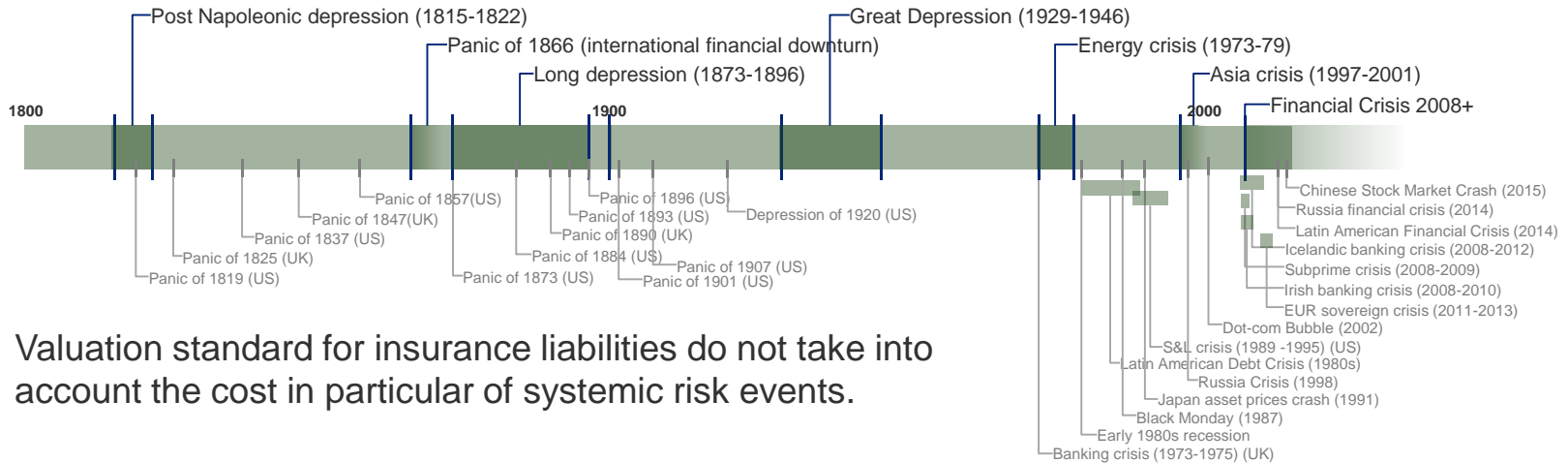

Valuation standard for insurance liabilities do not take into account the cost in particular of systemic risk events.

History has shown that systemic financial crisis (global and national) are frequent and immensely expensive. Held-to-maturity approaches that are being introduced give incentives to increase exposures to systemic risk (long-dated liabilities, illiquid assets). Once the next financial crisis occurs, default and liquidity risk will increase and insurers and pensions will require fresh capital at a high cost. The depleted capital positions due to having brought forward all expected asset returns will then likely for many require a bailout by taxpayers or cuts of benefits for current and future beneficiaries.

**Valuation standards of insurance liabilities have to be defined such that they take into account the costs due to financial crises. For valuation of insurance liabilities with long durations, this is even more important than for capital standards.**

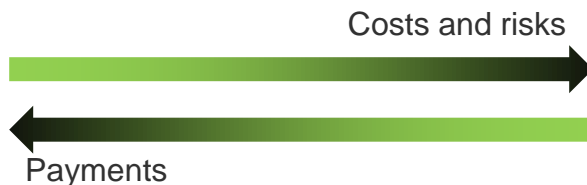

Hold-to-maturity approaches and compromised solvency systems are used to hide the true costs and the failings of past and current managers and policy makers

He pays, via reduced opportunities and the current generation saving on infrastructure, education and research

# The end



# Contact

Philipp Keller

Head Insurance Risk Management

Deloitte AG

Switzerland

Tel: +41 58 279 6290

Mobile: +41 79 874 2575

Email: [phkeller@deloitte.ch](mailto:phkeller@deloitte.ch)





Deloitte refers to one or more of Deloitte Touche Tohmatsu Limited (“DTTL”), a UK private company limited by guarantee, and its network of member firms, each of which is a legally separate and independent entity. Please see [www.deloitte.com/ch/about](http://www.deloitte.com/ch/about) for a detailed description of the legal structure of DTTL and its member firms.

Deloitte AG is a subsidiary of Deloitte LLP, the United Kingdom member firm of DTTL.

Deloitte AG is an audit firm recognised and supervised by the Federal Audit Oversight Authority (FAOA) and the Swiss Financial Market Supervisory Authority (FINMA).

This publication has been written in general terms and therefore cannot be relied on to cover specific situations; application of the principles set out will depend upon the particular circumstances involved and we recommend that you obtain professional advice before acting or refraining from acting on any of the contents of this publication. Deloitte AG would be pleased to advise readers on how to apply the principles set out in this publication to their specific circumstances. Deloitte AG accepts no duty of care or liability for any loss occasioned to any person acting or refraining from action as a result of any material in this publication.